

# 055 Roof Top Blox with 1"-3" Pipe Roller and Securing Bracket

BILL OF MATERIALS			
COMPONENT	PART NUMBER	QTY.	JOB QTY
Roof Top Blox	RTB-01	1	
1" - 3" Pipe Roller	ROL-05	1	
1/2" Threaded Rod	ROD-03	1	
1/2" Nuts	ROD-03	8	
1/2" Washers	ROD-03	4	
Securing Bracket	SCB-07	2	
M-1 Adhesive	ADH-12	10oz. Tube	
T.P.O. Primer	PRI-13	1 Pint	
# 12 X 3/4" Sheet Metal Screw	By Contractor	4	

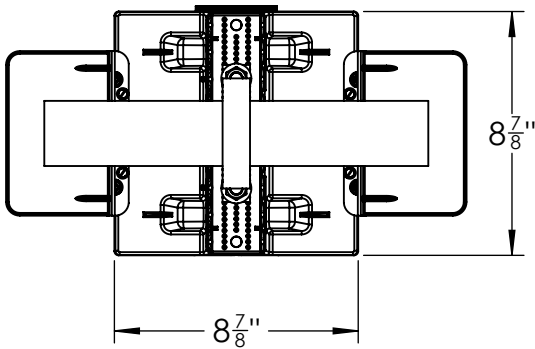

- ADH-12 Adhesive and SCB-07 brackets are recommended on all metal and smooth roofing membrane applications
- 1 Tube of ADH-12 bonds 10 pair of SCB-07
- 1 Pint of PRI-13 preps membrane for 35 pair of SCB-07
- PRI-13 Primer required on T.P.O. membranes
- Primer enhances all smooth membrane bonding

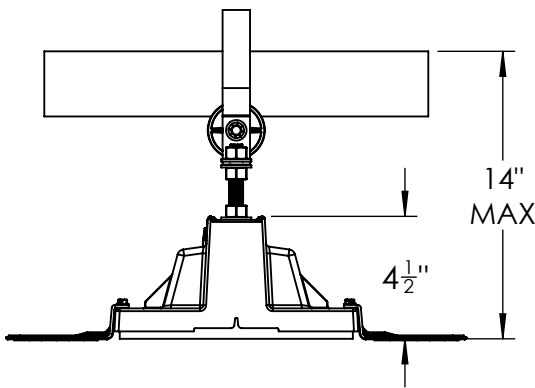

2 X #12 X 3/4"  
Sheet Metal Screw  
Thru Each SCB-07  
and into Blox

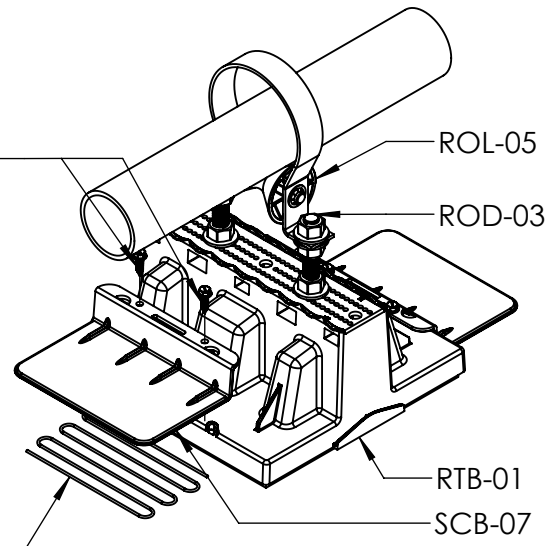
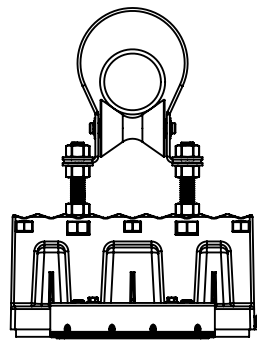

Apply ADH-12 Adhesive to cleaned surface under SCB-07. Do not apply ADH-12 below 32°F / 0°C

Job: \_\_\_\_\_  
 Date: \_\_\_\_\_ Rev: \_\_\_\_\_  
 Engineer: \_\_\_\_\_  
 Rep/Distributor: \_\_\_\_\_

**Specification:**  
 Roof top support blocks for gas piping, plumbing, HVAC, conduit, cable tray, and mechanical equipment shall be **Roof Top Blox (RTB-01)**. The support BLOX must be designed to eliminate roof penetrations, flashings or damage to roofing membrane. Support body shall be made of recycled UV-resistant Polypropylene Copolymer. Base platform material shall be 1" thick, 25psi, type 4 closed cell structural foam to distribute and evenly cushion loads. Support top surface shall have molded in pipe organizing saddles and strut mounting cradle. The top surface shall also have screw guide indents and engineered internal screw thread gripping feature. BLOX must accept 3/8" and 1/2" threaded rods (ROD-03) using side-entry nut slots to allow fast top side assembly and piping height adjustments. Aluminum rollers (ROL-05 or ROL-06) shall be installed on long piping runs. Securing brackets (SCB-07) and adhesive (ADH-12) recommended for permanently securing BLOX into its final installed position, anchoring against wind, rain and snow loads.

**Roof Top®**  
**BLOX**  
 Adjustable Piping Support  
 US PAT. 7,731,131 CAN. PAT. 2,675,158

RTB-01 w/ ROL-05 and SCB-07

Max Load Per Blox:  
 Single Point: 250 lb/113 kg  
 Dual Point or Strut-Mounted Load: 350 lb/158 kg

P: (860) 979-0345 www.rooftopblox.com  
 F: (860) 871-9218 info@rooftopblox.com

1. Remove all loose gravel under Roof Top Blox base
2. Space Blox every 7' along piping system
3. Install piping system low on Blox for best stability
4. Maximum 14" overall piping height on single Blox
5. Use rollers on long pipe runs for thermal expansion
6. Maximum temperature rating is 200F/93C
7. Use STR-04 strut for point loads over 250lbs/113kg
8. Use 15ft-lb max torque and Loctite on Blox jamb nuts
9. Use SCB-07 Brackets to secure Blox in final position
10. Check membrane Mfg. and adhesive compatibility
11. Check local codes and regulations prior to installation